

Corrosion Behavior of Coated and Uncoated Nickel-Titanium Orthodontic Wires in Artificial Saliva with Short-term Prophylactic Fluoride Treatment

Katić, Višnja; Ivanković Buljan, Zorana; Špalj, Stjepan; Otmačić
Ćurković, Helena

Source / Izvornik: **International Journal of Electrochemical Science, 2018, 13, 4160 - 4170**

Journal article, Published version

Rad u časopisu, Objavljena verzija rada (izdavačev PDF)

<https://doi.org/10.20964/2018.05.69>

Permanent link / Trajna poveznica: <https://um.nsk.hr/um:nbn:hr:184:814261>

Rights / Prava: [Attribution 4.0 International](#)/[Imenovanje 4.0 međunarodna](#)

Download date / Datum preuzimanja: **2024-07-17**



Repository / Repozitorij:

[Repository of the University of Rijeka, Faculty of
Medicine - FMRI Repository](#)



Corrosion Behavior of Coated and Uncoated Nickel-Titanium Orthodontic Wires in Artificial Saliva with Short-term Prophylactic Fluoride Treatment

Višnja Katić^{1,*}, Zorana Ivanković Buljan^{2,3}, Stjepan Špalj¹, Helena Otmačić Ćurković⁴

¹ Department of Orthodontics, Faculty of Medicine, University of Rijeka, Rijeka, Croatia;

² Department of Orthodontics, Faculty of Medicine, University of Split, Split, Croatia

³ Faculty of Medicine, University of Mostar, Mostar, Bosnia and Hercegovina;

¹ Department of Orthodontics, Faculty of Medicine, University of Rijeka, Rijeka, Croatia;

⁴ Department of Electrochemistry, Faculty of Chemical Engineering and Technology, University of Zagreb, Zagreb, Croatia;

*E-mail: visnja.katic@medri.uniri.hr

Received: 7 February 2018 / Accepted: 5 March 2018 / Published: 10 April 2018

The objective was to evaluate and compare the corrosion stability of nickel-titanium (NiTi) wires with various coatings in the course of a weekly prophylactic regime. Uncoated (uNiTi), nitride (NNiTi) and rhodium (RhNiTi)-coated nickel-titanium archwires were immersed in artificial saliva for 28 days. Once per week, for five minutes, the wires were immersed in different topical fluoride gels. Wires from every experimental group were subjected to electrochemical testing (open circuit potential, electrochemical impedance spectroscopy (EIS) and cyclic polarization). The corrosion resistance of the uNiTi and NNiTi wires did not differ, regardless of the immersion media. The corrosion resistance of the RhNiTi wires decreased after prolonged exposure to artificial saliva and repeated exposure to re-mineralizing agents with low HF concentration. In contrast, the resistance to corrosion increased after repeated exposure to re-mineralizing agents with high HF concentration. EIS testing showed that uNiTi and NNiTi in all media and RhNiTi in the highest HF media displayed a surface oxide coating, whereas RhNiTi in all other media showed an outer porous oxide layer above the compact oxide layer. Repeated application of prophylactic agents with high fluoride concentrations decreases the barrier properties of the surface coating on uNiTi and NNiTi wires and disrupts formation of the porous layer of corrosion products inside the pores of the noble coating on RhNiTi wires.

Keywords: cyclic polarization scan; electrochemical impedance spectroscopy; nickel-titanium wire; surface coating; topical fluoride.

1. INTRODUCTION

Corrosion of NiTi wires results in nickel and titanium ion release as well as increased friction and discoloration of the teeth and surrounding structures [1, 2]. Additionally, hypertrophic gingival

tissue and hypersensitivity reactions were observed together with loss of aesthetic appearance [3, 4]. In intermetallic compounds such as NiTi alloy, Ni atoms are not strongly held within the alloy, and their release into the oral cavity can either contribute to the onset of hypersensitivity reactions or can decrease the risk of future hypersensitivity reactions, depending on other confounding factors such as previous piercing [5]. Research has shown that NiTi alloys have high corrosion resistance due to formation of a passive TiO₂ surface layer. However, various surface coatings on basic NiTi wires are continuously promoted as additional protection from leaching of allergenic Ni ions. Titanium nitride (TiN) is a hard ceramic structure that is often implemented for surface improvement [6-8]. An aesthetic type of coating consists of a whitish anti-reflective noble metallic layer of gold and rhodium [9]. It was found that nitrification improves the anticorrosive properties of the NiTi wires in artificial saliva, but rhodium coating does not [8, 10]. After clinical use, the loss of aesthetic appearance of the rhodium coating was evident [3, 4].

Orthodontic treatment is associated with increased susceptibility to caries [11]. Fluoride gels for adjuvant oral care at home are low in cost, easily available and simple to use, and brushing the teeth once a week for five minutes with fluoride gel is recommended [12]. The sticky consistency of prophylactic gels enables prolonged contact of fluoride not only with the teeth but also with the wires. Fluoride has a destructive influence on the corrosion stability of titanium and NiTi wires, promoting localized corrosion phenomenon and disabling re-passivation of the protective oxide layer on the coating [13-15]. Both the hydrofluoric acid (HF) concentration and concentration of fluorides influence the corrosion resistance and ion release from NiTi wires [16, 17]. Electrochemical methods are appropriate for assaying the material behaviors in corrosive media because they offer insight into the properties of the surface oxide coating (through electrochemical impedance spectroscopy (EIS) measurements) and the corrosion rate (through the polarization measurements) [18]. Electrochemical testing of commercially available nitride NiTi showed improvement in corrosion resistance in artificial saliva and fluoride mouthwash [7, 8]. The occurrence of pitting or generalized corrosion on the bare NiTi alloy was attributed to and dependent on the fluoride concentration [19]. No data are available with respect to electrochemical testing of rhodium-coated wires in the fluoride solutions. It is unknown how the surface coating behaves after repeated exposure of the wires to fluoride re-mineralizing agents, neither for the uncoated nor for the nitride- and rhodium-coated NiTi.

Therefore, the aim of this study is to evaluate and compare the corrosion stability of uncoated and nitride- and rhodium-coated nickel-titanium wires in artificial saliva and three different topical fluoride gels in the course of a weekly prophylactic regime.

2. EXPERIMENTAL

2.1. Materials

This study investigated three commercially available preformed superelastic NiTi orthodontic wire types, i.e., 0.508 mm × 0.508 mm:

- 1) NiTi with an untreated surface (uNiTi)
- 2) Rhodium-coated NiTi (RhNiTi)

3) Nitride-coated NiTi (NNiTi)

Artificial saliva (AS) solution (1.5 g/L KCl, 1.5 g/L NaHCO₃, 0.5 g/L NaH₂PO₄–H₂O, 0.5 g/L KSCN, 0.9 g/L lactic acid, pH 4.8) was prepared, as used in previous studies [8].

Three commercial fluoride agents were used in this investigation: Elmex gelée (Elmex), Mirafluor-k-gel (Mirafluor) and MI Paste Plus (MI Paste). These fluoride agents have identical methods of application but differ in content of fluoride ions (F⁻), hydrofluoric acid (HF) concentrations and pH values. The HF concentration was calculated as described previously [17]. The pH value was measured using a pH meter (MP 220, Mettler Toledo Int., Greifensee, Switzerland). The concentration of F⁻ was measured with an ion-selective-electrode Expandable Ion Analyzer (EA 940, Orion Research, Beverly, USA) instrument. During these measurements, the re-mineralizing agents were incubated in a water bath at 37 °C.

2.2. Prophylactic immersion protocol

Corrosion experiments were performed on wire specimens with a length of 50 mm, which were immersed in 10 mL of artificial saliva solution and incubated in a water bath at 37 °C. At intervals of one week, the wire samples were removed from the artificial saliva and immersed in the prophylactic agents for 5 minutes at 37 °C. After immersion in the prophylactic agents, the wires were rinsed with dH₂O prior to immersion in fresh saliva samples. This protocol imitated the dynamics of application for prophylactic fluoride agents, as recommended by the manufacturers. One group of samples for every wire type was immersed in artificial saliva alone, and the total immersion time for all specimens was 28 days. All experiments were performed in triplicate.

2.3. Electrochemical studies

Upon completion of the prophylactic protocol, wire specimens from every experimental group were subjected to electrochemical testing in artificial saliva. From the halved arch forms, specimens were prepared with a length of 50 mm, testing area of 30 mm long (distal straight end of the wires) and surface area of 60.96 mm². Segments exposed to the testing were separated with isolating polish at the tip on one side and at a one-centimeter-long area located before the one centimeter of bare wire, which was connected to the potentiostat. Three specimens were prepared from every experimental group. The corrosion tests were performed using a three-electrode cell connected to a potentiostat (PAR 263A) and frequency response detector (1025, Ametek, Oak Ridge, USA). A saturated calomel electrode (SCE) and platinum wire were used as the reference and counter electrode, respectively. All potentials mentioned in this paper refer to SCE. All measurements were conducted at 37 ± 1 °C in fresh artificial saliva solution with the same chemical composition as described above. Electrochemical testing consisted of three steps. First, the open circuit potential (OCP) was monitored for 2 hours to obtain a stable value of OCP. Second, electrochemical impedance spectroscopy (EIS) was performed. Measurements were conducted at open circuit potential. The amplitude of the voltage perturbation was 10 mV_{rms}, and the impedance measurements were conducted in the frequency range from 100 kHz to 10 mHz. The following impedance spectra parameters were obtained: resistance of the porous layer (R_{po}), capacity of the porous layer (C_{po}), coefficient of the porous layer (n_{po}), resistance of the oxide

layer (R_{ox}), capacity of the oxide layer (C_{ox}), and coefficient of the oxide layer (n_{ox}). Finally, a cyclic polarization scan was conducted starting from -300 mV *versus* OCP up to the potential at which the current density reached $100 \mu\text{Acm}^{-2}$, and at that point, the scanning was reversed. The cyclic polarization was performed at a scan rate of 1 mVs^{-1} . From the cyclic polarization curves, the following electrochemical parameters were determined: corrosion current density (i_{corr}), corrosion potential (E_{corr}), breakdown potential (E_{bd}), and re-passivation potential (E_{rp}).

3. RESULTS

3.1. Properties of prophylactic fluoride agents

Details of the pH, F^- and HF concentrations are listed in Table 1. The MI Paste had both the lowest F^- and HF concentrations, whereas the Elmex had the highest F^- concentration, and the Mirafluor had the highest HF concentration.

Table 1. pH, fluoride ions (F^-) and hydrofluoric acid (HF) concentrations in the tested re-mineralizing agents.

re-mineralizing agent	pH	fluoride (ppm)	HF (ppm)
MI Paste	6.6	848.2	0.32
Mirafluor	5.1	6068.9	71.31
Elmex	5.5	11520	53.88

3.2. Electrochemical testing

Representative polarization curves of the archwire samples obtained via the cyclic polarization method indicate that a difference exists between the examined wires, i.e., the uNiTi and NNiTi and also the RhNiTi (Figure 1).

The main difference is observed on the anodic polarization curves. The breakdown of passive film occurs at significantly lower potentials for the RhNiTi wire than for the other two wire types (Figure 1 and Table 2). However, the RhNiTi samples showed the noblest corrosion potential and resulted in the narrowest passive region, i.e., the passive film can be much more easily destroyed than on the other two wire types. The corrosion current densities, (Table 2) are also the highest for RhNiTi (except for the sample treated with high HF agents).

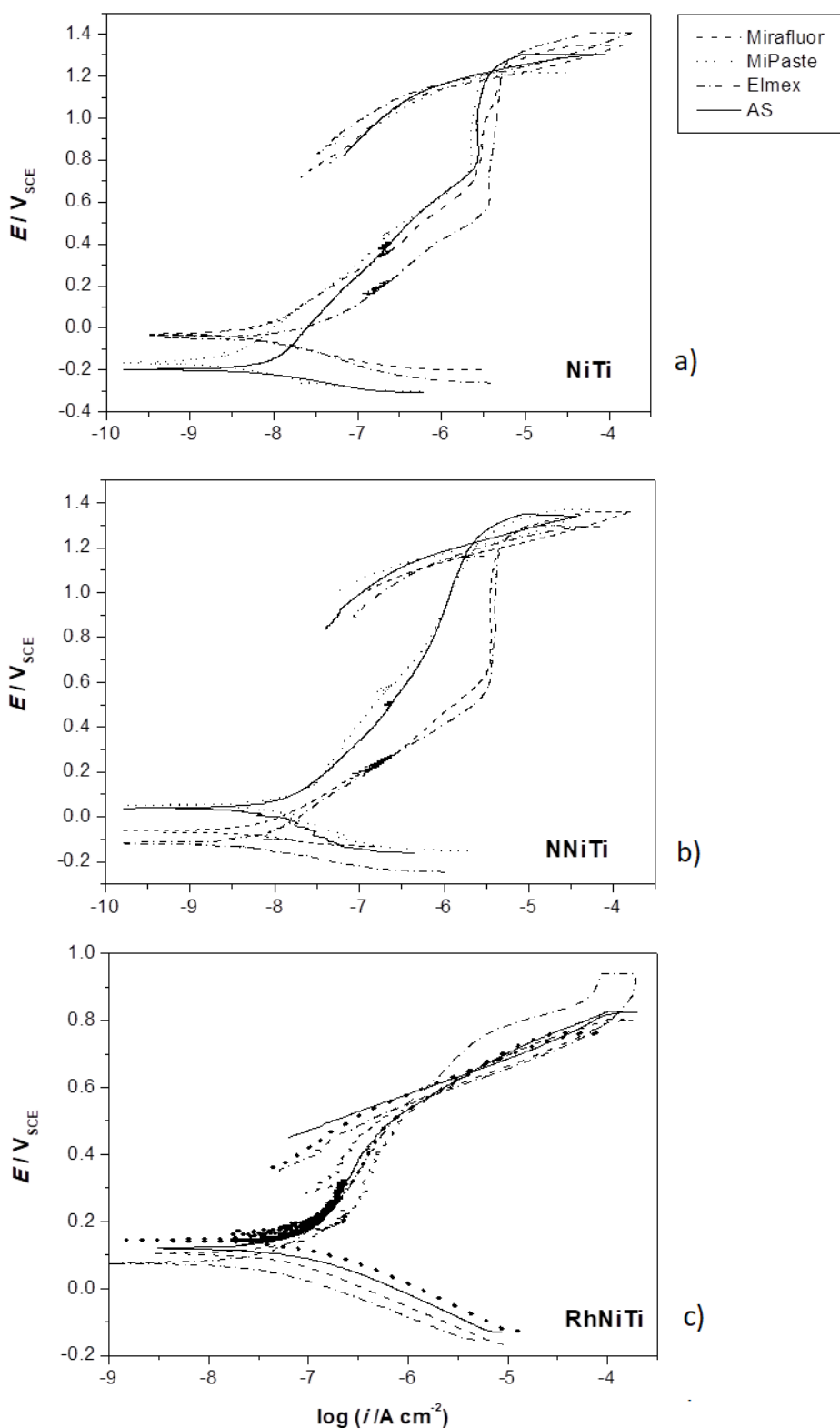

Figure 1. Cyclic polarization curves for uncoated (uNiTi) (a), nitrified (NNiTi) (b) and rhodium-coated (RhNiTi) (c) wires after exposure to artificial saliva (AS) and prophylactic agents (MI Paste, Elmex and Miraflur).

Table 2. Electrochemical parameters determined from the cyclic polarization curves for uncoated (uNiTi), nitrified (NNiTi) and rhodium-coated (RhNiTi) wires. The results are shown as “arithmetic mean (standard deviation)”.

Variable	Media type	uNiTi	NNiTi	RhNiTi
i_{corr} (nAcm ⁻²)	AS	11 (9)	8 (4)	106 (30)
	AS+MiPaste	8 (10)	16 (14)	133 (24)
	AS+Elmex	25 (27)	7 (6)	111 (100)
	AS+Mirafleur	8 (5)	15 (17)	49 (5)
E_{corr} (mV _{SCE})	AS	-136 (84)	7 (101)	154 (31)
	AS+MiPaste	-102 (130)	18 (24)	143 (11)
	AS+Elmex	-56 (43)	-114 (36)	95 (24)
	AS+Mirafleur	-51 (23)	-64 (14)	111 (11)
E_{bd} (mV _{SCE})	AS	1149 (231)	1287 (35)	619 (118)
	AS+MiPaste	1210 (65)	1306 (14)	666 (50)
	AS+Elmex	1295 (7)	1050 (304)	746 (19)
	AS+Mirafleur	1305 (23)	1247 (47)	616 (81)
E_{rp} (mV _{SCE})	AS	1097 (210)	1187 (27)	595 (53)
	AS+MiPaste	1162 (40)	1193 (7)	607 (61)
	AS+Elmex	1208 (12)	1042 (314)	618 (87)
	AS+Mirafleur	1214 (22)	1227 (63)	615 (29)

i_{corr} - corrosion current density; E_{corr} - corrosion potential; E_{bd} - breakdown potential; E_{rp} - re-passivation potential; AS - artificial saliva.

For the uNiTi and NNiTi wires, the uniform corrosion rate was not significantly influenced by the prophylactic agent treatments. The polarization curves showed that treatment with high HF/F⁻ concentrations increased the corrosion current densities in the passive region. Thus, the barrier properties of surface layer on both wire types decreased after treatment with high fluoride-containing agents.

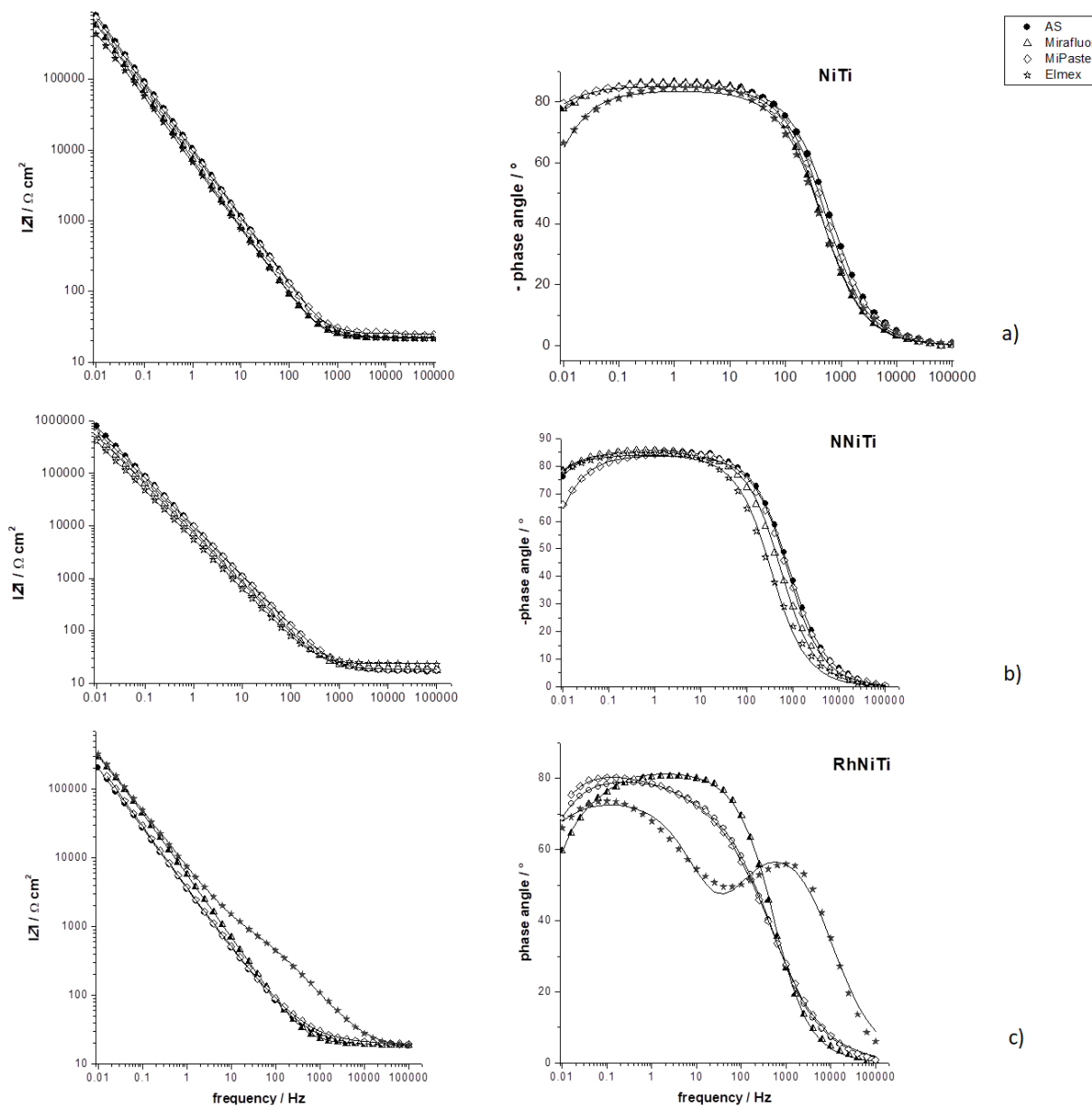

Figure 2. Bode plots for uncoated (uNiTi) (a), nitrified (NNiTi) (b), and rhodium-coated (RhNiTi) (c) wires after exposure to artificial saliva (AS) and prophylactic agents (MI Paste, Elmex and Mirafleur). Symbols depict experimental data, and lines indicate fit of the experimental data to the chosen model.

The impedance spectra for the uNiTi and NNiTi wires in all media (Figure 2a, b) showed only one broad phase angle maximum, which is typical for metals covered by a passive layer. In all media except the high HF agent (Mirafleur), two phase angle maxima occurred on the impedance spectrum for the RhNiTi wire (Figure 2c), implying the presence of two capacitive elements, which is typical for substrates with porous surface coatings. The lines in Figure 3 describe the fit of the proposed models to the experimental results.

Electrical equivalent models that describe the observed corrosion systems were chosen (Figure 3). For the uNiTi and NNiTi wire in all media and for the RhNiTi wire in the high HF agent, a simple

model was applied that consists of a constant phase element (CPE) describing the oxide capacitance (C_{ox}) in parallel with the oxide resistance (R_{ox}) connected in series with the electrolyte resistance (R_e) (Figure 3a). For the RhNiTi wire in all other media, one additional capacitance-resistance circuit was necessary to model the experimental results. These differences were ascribed to the pore resistance (R_{po}) of the porous upper layer and its capacitance (C_{po}) (Figure 3 b).

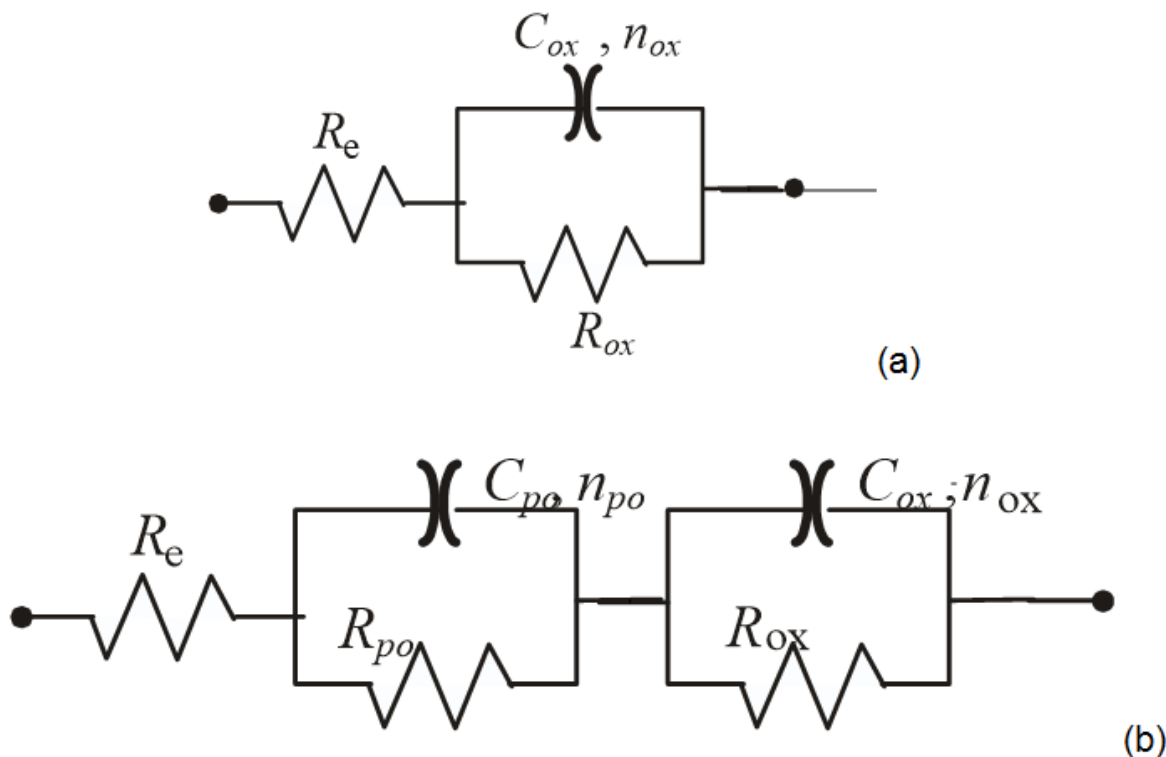

Figure 3. Schemes of the electrical equivalent models: a) uncoated (uNiTi) and nitrified (NNiTi) wire in all media and rhodium-coated (RhNiTi) wire in high HF agent, b) RhNiTi wire in all other media.

Exposure of the uNiTi wire to artificial saliva for a longer period of time resulted in increased R_{ox} . Lower values for R_{ox} and the highest values of C_{ox} were obtained for the samples treated with high HF/F⁻ concentrations (Table 3).

For the NNiTi wire, the R_{ox} and C_{ox} values were similar those of the uNiTi wire. The oxide capacitance increased as the HF/F⁻ concentration increased. In the same manner, R_{ox} showed the lowest value in high HF/F⁻ agents, indicating the lowest protective quality of the oxide layer (Table 3).

The RhNiTi samples showed lower R_{ox} and higher C_{ox} values compared with the other two wire types. The RhNiTi samples treated with the agent with the highest HF concentration did not exhibit the porous layer of the corrosion products, as opposed to the artificial saliva or low fluoride agent (Table 3). Still, this compact oxide layer showed weaker protective properties compared with the uNiTi and NNiTi wires. Additionally, noted were multiple higher values of the porous layer capacitance compared with the oxide layer and an even more obvious difference in the resistance values of the porous layer compared with the resistance values of the oxide layer.

Table 3. Impedance spectra parameters for uncoated (uNiTi), nitrified (NNiTi) and rhodium-coated (RhNiTi) wires. Results are shown as “arithmetic mean (standard deviation)”.

wire type	sample	$R_{po}/$ $K\Omega cm^2$	$C_{po}/$ $\mu F cm^{-2}$	n_{po}	$R_{ox}/$ $M\Omega cm^2$	$C_{ox}/$ $\mu F cm^{-2}$	n_{ox}
uNiTi	AS				6.9 (1.2)	23.5 (5.4)	0.95 (0.01)
	AS + Mirafleur				3.4 (1.1)	26.6 (3.0)	0.96 (0.01)
	AS + MI Paste				8.2 (1.1)	22.6 (1.2)	0.94 (0.02)
	AS + Elmex				1.5 (0.4)	35.8 (15.1)	0.94 (0.01)
NNiTi	AS				7.5 (7.6)	25.3 (3)	0.93 (0.21)
	AS + Mirafleur				5.5 (1.3)	35.3 (6.4)	0.94 (0.01)
	AS + MI Paste				5.1 (4.7)	25.6 (2.9)	0.93 (0.02)
	AS + Elmex				4.1 (2.7)	50.1 (6.4)	0.93 (0.01)
RhNiTi	AS	13.8 (23.4)	305.8 (140)	0.61 (0.07)	2.5 (2.6)	86 (5.3)	0.93 (0.04)
	AS + Mirafleur				0.9 (0.7)	52.3 (5)	0.90 (0.01)
	AS + MI Paste	8.6 (14.5)	207.3 (121.9)	0.56 (0.02)	1.9 (1.6)	86 (15.2)	0.91 (0.02)
	AS + Elmex	0.6 (0.1)	4.5 (146.8)	0.71 (0.03)	6.5 (6.1)	90.2 (34.2)	0.81 (0.02)

AS - artificial saliva; R_{po} – resistance of the porous layer; C_{po} - capacity of the porous layer; n_{po} - coefficient of the porous layer; R_{ox} - resistance of the oxide layer; C_{ox} - capacity of the oxide layer; n_{ox} – coefficient of the oxide layer.

4. DISCUSSION

The results from the electrochemical measurements indicate higher general corrosion rates and higher susceptibility to localized corrosion of RhNiTi wire compared with the uNiTi and NNiTi wires. The noble metal coating is less effective in corrosion protection of the NiTi substrate than the oxide layer formed on uNiTi or nitride layer formed on NNiTi. The corrosion of the substrate, which occurs in the pores of the noble coating on RhNiTi, is enhanced by formation of a galvanic couple between the noble coating and NiTi [8].

After repeated exposure to the prophylactic agents containing high HF/F⁻ concentration, the uNiTi and NNiTi wires show a more negative corrosion potential, in agreement with the previously reported influence of fluoride on the corrosion potential of titanium alloys [7, 13-16, 19, 20]. This shift in the potential also affects the intensity of galvanic corrosion because the lowest corrosion current densities were measured for the RhNiTi wire after exposure to the high HF concentration. Compared

with the artificial saliva alone, repeated exposure to the prophylactic gels caused a decrease in the barrier properties of the surface coating on both uNiTi and NNiTi wire types.

The impedance spectra for the uNiTi and NNiTi wires indicate the presence of the surface oxide layer [6, 21], and for the RhNiTi wire, the additional *R-C* circuit implies that an outer porous oxide layer is present above the inner compact oxide layer [22]. CPE is used instead of the ideal capacitance because it better describes the real surfaces [23, 24]. The discrepancy from the ideal capacitive behavior is indicated with coefficient *n*, and it is affected by the properties of the surface (surface roughness, porosity) [23, 24]. The values of the coefficient *n* can vary from 0.5 to 1, and the more homogenous the surface, the closer *n* approaches a value of 1, i.e., closer to the ideal capacitive behavior. The oxide capacitance is inversely proportional to the oxide thickness.

An increase in the oxide resistance occurs after prolonged exposure of the uNiTi wires to the artificial saliva alone. In contrast, repeated application of the gels to high HF/F⁻ concentrations caused deterioration of the surface oxide layer on the uNiTi wires, which was also reflected in lower values of oxide resistance and higher oxide capacitance. The repeated application of agents with high HF/F⁻ concentration caused a decrease in the protective quality of the oxide layer. An increase in capacitance was noted due to the transformation of TiN into TiO₂ [7] as well as the incorporation of F⁻ ions into the surface layer. This assumption is in agreement with the fact that *C_{ox}* increases with the increase in fluoride concentration in the chosen re-mineralizing agents.

Variability within the one batch of the same type of wires, differences in the chemical structure of the prophylactic agents, and impurities and pores on the wire surfaces are all factors that most likely affect the strength of this model.

5. CONCLUSIONS

The corrosion resistance of uNiTi and NNiTi wires decreases after repeated application of agents with high HF/F⁻ concentration due to the deterioration of the protective quality of the surface oxide layer.

The resistance to corrosion of the RhNiTi wires is decreased after prolonged exposure to the artificial saliva environment and repeated exposure to re-mineralizing agents with low HF concentration. In contrast, after repeated exposure to re-mineralizing agents with high HF concentration, the resistance to corrosion increases.

EIS testing showed that NiTi and NNiTi in all media and RhNiTi in the highest HF media showed surfaces covered with a compact oxide layer, whereas RhNiTi in all other media showed the presence of an outer porous oxide layer above the inner compact oxide layer.

ACKNOWLEDGEMENTS

This research was supported by the Croatian Science Foundation (HRZZ) grant number IP-2014-09-7500.

References

1. R. Lindsten and J. Kurol, *J. Orofac. Orthop.*, 58(1997)100.
2. M. C. L. S. Genelhu, M. Marigo, L. F. Alves-Oliveira, L. C. C. Malaquias and R. S. Gomez, *Am. J. Orthod. Dentofac. Orthop.*, 128(2005)378.
3. R. Rongo, G. Ametrano, A. Gloria, G. Spagnuolo, A. Galeotti, S. Paduano, R. Valletta and V. D'Antò, *Angle Orthod.*, 84(2014)665.
4. T. G. Bradley, D. W. Berzins, N. Valeri, J. Pruszynski, T. Eliades and C. Katsaros, *Eur. J. Orthod.*, 36(2014)290.
5. R. Fors, B. Stenberg, H. Stenlund and M. Persson, *Contact Dermatitis*, 67(2012)342.
6. C. Liu, P. K. Chu, G. Lin and D. Yang, *Corros. Sci.*, 49(2007)3783.
7. M. Iijima, T. Yuasa, K. Endo, T. Muguruma, H. Ohno and I. Mizoguchi, *Dent. Mater. J.*, 29(2010)53.
8. V. Katić, H. Otmačić Čurković, D. Semenski, G. Baršić, K. Marušić and S. Špalj, *Angle Orthod.*, 84(2014)1041.
9. M. Iijima, T. Muguruma, W. A. Brantley, H. C. Choe, S. Nakagaki, S. B. Alapati and I. Mizoguchi, *Angle Orthod.*, 82(2012)319.
10. M. Rincic Mlinaric, L. Kanizaj, D. Zuljevic, V. Katic, S. Spalj and H. Otmacic Curkovic, *Mater Corros.*, (2017)1.
11. G. C. Heymann and D. Grauer, *J. Esthet. Restor. Dent.*, 25(2013)85.
12. S. Hadler-Olsen, K. Sandvik, M. A. El-Agroudi and B. Øgaard, *Eur. J. Orthod.*, 34(2012)633.
13. X. Li, J. Wang, E. Han and W. Ke, *Acta Biomater.*, 3(2007)807.
14. M. Mirjalili, M. Momeni, N. Ebrahimi and M. H. Moayed, *Mater. Sci. Eng. C Mater. Biol. Appl.*, 33(2013)2084.
15. T. H. Lee, C. C. Wang, T. K. Huang, L. K. Chen, M.Y. Chou, H. H. Huang, *J. Alloys. Compd.*, 488(2009)482.
16. M. Nakagawa, S. Matsuya, T. Shiraishi and M. Ohta, *J. Dent. Res.*, 78(1999)1568.
17. V. Katic, L. Curkovic, M. Ujevic Bosnjak, K. Peros, D. Mandic and S. Spalj, *Dent. Mater. J.*, 36(2017)149.
18. T. Eliades and W. A. Brantley, *Orthodontic Applications of Biomaterials*, Woodhead Publishing, (2016) Duxford, UK.
19. E. J. Kassab and J. P. Gomes, *Angle Orthod.*, 83(2013)864.
20. I. Milošev, B. Kapun and V. S. Selih, *Acta Chim. Slov.*, 60(2013)543.
21. R. Hang, S. Ma, V. Ji and P. K. Chu, *Electrochim. Acta.*, 55(2010)5551.
22. J. M. Bastidas, M. Saiki, S. O. Rogero, I. Costa and J. L. Polo, *J. Appl. Electrochem.*, 32(2002)487.
23. J. Creus, H. Mazille and H. Idrissi, *Surf. Coat. Technol.*, 130(2000)224.
24. S. H. Ahn, J. H. Lee, J. G. Kim and J. G. Han, *Surf. Coat. Technol.*, 177–178(2004)638.